

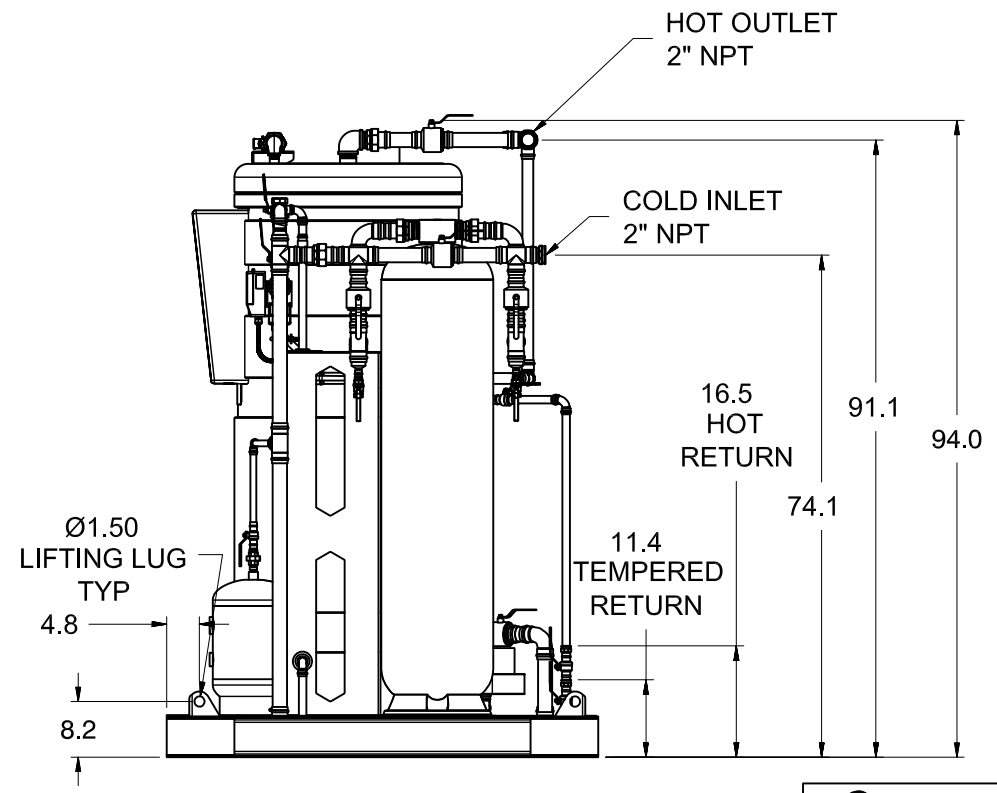

Minimum Clearance from Combustibles	Recommended Service Clearances
Zero clearance from sides and rear of skid, 24" from front of skid, 15" from top.	Zero clearance from rear, 18" from all other sides of skid. Check local and national codes for additional clearance requirements.

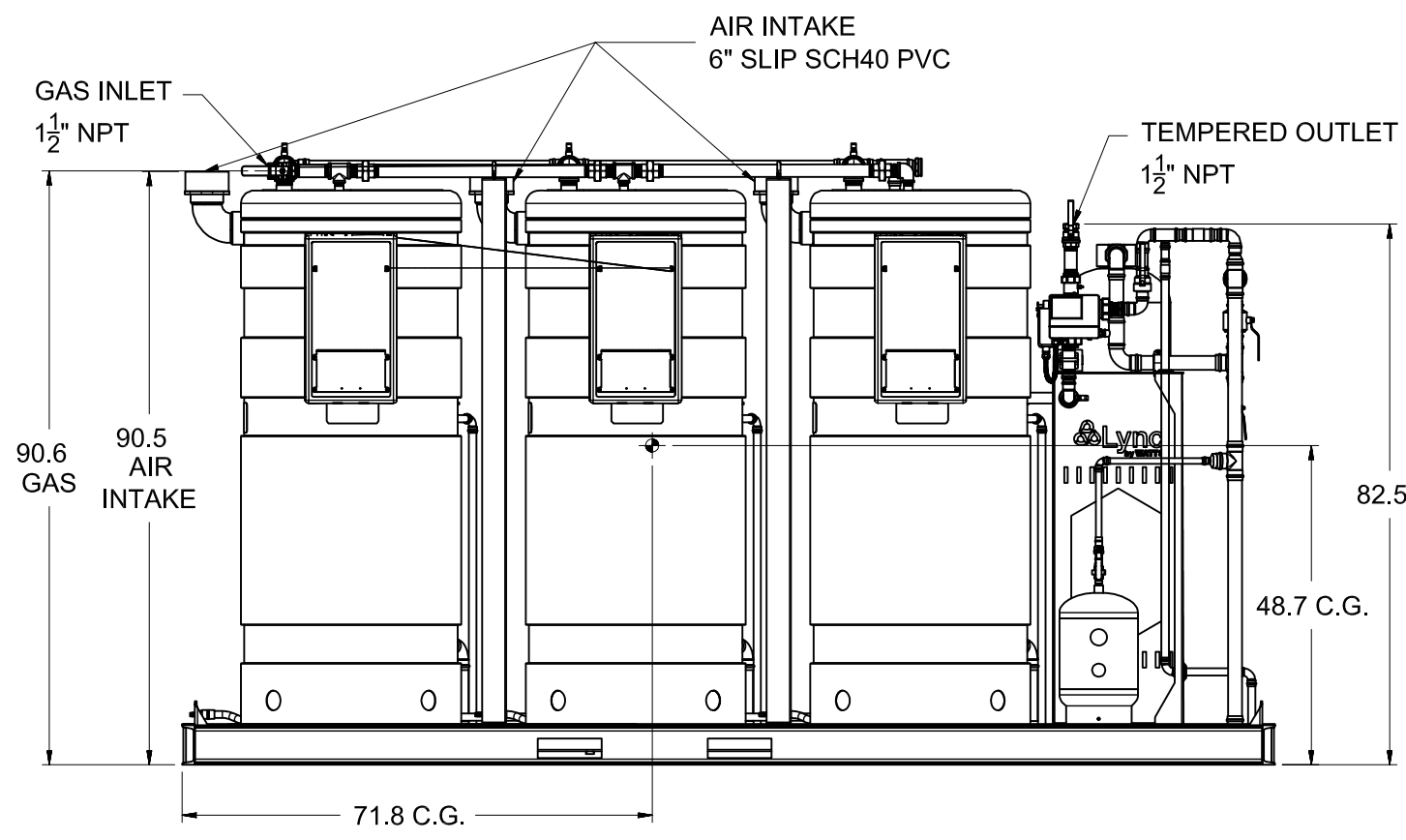

- NOTES:
1. NEUTRALIZER KIT (PROVIDED) AND RELIEF VALVE PIPED TO DRAIN BY CONTRACTOR.
 2. LYNC RESERVES THE RIGHT TO MODIFY DIMENSIONS WITHOUT PRIOR NOTICE.
 3. PIPING LOCATIONS ARE APPROXIMATE. FINAL DIMENSIONS MAY VARY DUE TO MANUFACTURING TOLERANCE.
 4. DO NOT RIG FROM SYSTEM PIPING.
 5. USE INDUSTRY STANDARD SAFE RIGGING METHODS, SUCH AS STRAPPING AROUND THE LC SERIES' BASE ASSEMBLY AND SPREADER BARS WHEN ATTEMPTING TO LIFT OR MOVE THIS PRODUCT. STANDARD FORKLIFTS ARE NOT ABLE TO SAFELY MOVE THE LC SERIES PACKAGES. A CRANE MAY BE REQUIRED DEPENDING ON THE SPECIFIC INSTALLATION.

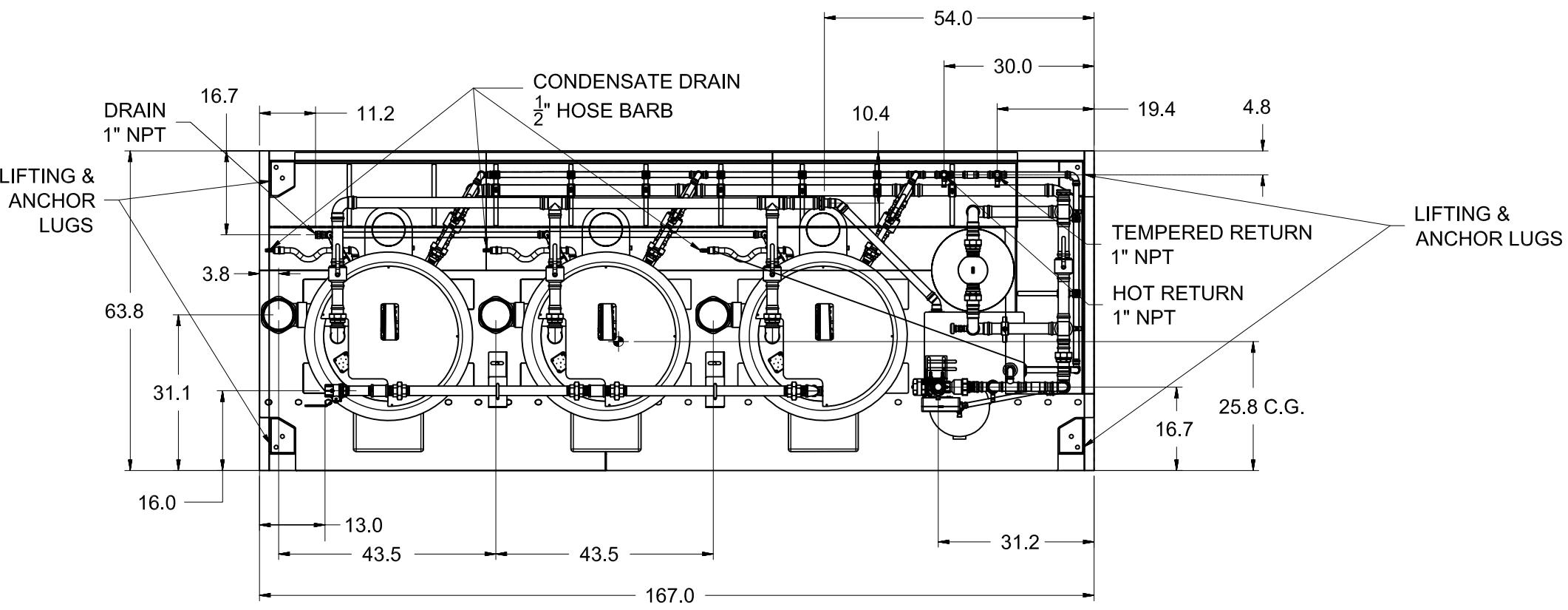

Blauvelt, NY
Fort Worth, TX
www.lyncbywatts.com

TITLE DIMENSIONAL DRAWING FOR LC-Q-2100 & -2400 3-UNIT SERIES			
DWN.BY <u>HCR</u>	DATE <u>9/24/2021</u>	DWG. NO.:	REV.
SCALE <u>NTS</u>		SD-L-1234	A
REV.BY <u>K.S.</u>	DATE <u>7/25/2022</u>	SHEET	1 OF 1