

# Installation, Operation and Maintenance Manual

## Lync AEGIS



### Disclaimer

The information contained in this manual is subject to change without notice from Watts Heating and Hot Water Solutions LLC dba Lync by Watts ("Lync"). Lync makes no warranty of any kind with respect to this material, including, but not limited to, implied warranties of merchantability and fitness for a particular application. Lync is not liable for errors appearing in this manual, nor for incidental or consequential damages occurring in connection with the furnishing, performance, or use of these materials.

### Hot Water Solutions

Lync • 425 W Everman Pkway, St. 101 • Fort Worth, TX 76134

USA: T: (817) 335-9531

Technical Support • (800) 433-5654 (ext. 3) • Mon-Fri, 8 am - 5 pm CST

© 2022 LYNC

## CONTENTS

<b>1. SAFETY CONSIDERATIONS .....</b>	<b>4</b>
1.1. General Warnings.....	5
1.2. Safety Precautions .....	5
<b>2. INTRODUCTION.....</b>	<b>6</b>
2.1. Aegis Models .....	6
2.2. Unit Control.....	6
2.3. Sequence Of Operation .....	7
2.4. Version With Cool Recovery (Air Source Unit Only) .....	8
2.5. Domestic Hot Pump Management.....	9
2.6. Superheat Set Limit .....	9
2.7. High Inlet Temperature (Hit) Function .....	10
2.8. High Pressure Set Point Calculation .....	10
2.9. Anti-Legionella .....	10
2.1.1. Phase 1 .....	11
2.1.2. Phase 2 .....	11
<b>3. INSTALLATION.....</b>	<b>13</b>
3.1. Spaces For Installation .....	14
3.2. Anti-Vibration Mounts .....	14
3.2.1. Rubber Anti-Vibration Mounts .....	14
3.3. General Recommendations For Hydraulic Connections .....	15
3.3.1. Recommended Hydraulic Circuit .....	16
3.3.2. Key Considerations For Water Piping .....	16
3.4. Lifting And Transport .....	17
3.5. Removing Transportation Braces.....	17
3.6. Lifting And Transport (Aegis A Air To Water Units).....	18
<b>4. HYDRAULIC CONNECTION.....</b>	<b>20</b>
4.1. Hydraulic Connection To The Exchanger.....	20
4.2. Minimum Source Water Content In The Plant.....	20
4.3. Water Composition .....	21
4.4. Discharge of Safety Valves .....	21
4.5. Condensate Disposal .....	22
<b>5. ELECTRIC CONNECTIONS.....</b>	<b>23</b>
5.1. Overview.....	23
5.2. Fan Speed Controller .....	23
5.3. Powering The Crankcase Heater .....	24
5.4. Potential Free Contacts .....	24
5.5. Controller Function .....	24
<b>6. STARTUP .....</b>	<b>25</b>
6.1. Preliminary Verifications .....	25
6.2. Verifications During Operation.....	25

---

<b>7. CALIBRATING CONTROL COMPONENTS.....</b>	<b>26</b>
<b>8. DECOMMISSIONING .....</b>	<b>27</b>
8.1. Seasonal Shutdown.....	27
8.2. Emergency Stop .....	27
<b>9. PERIODIC MAINTENANCE AND INSPECTIONS.....</b>	<b>27</b>
9.1. Overview.....	28
9.2. Protection Of The Environment .....	28
<b>10. DISPOSAL OF THE UNIT .....</b>	<b>29</b>
<b>11. REFRIGERANT .....</b>	<b>30</b>
11.1. Refrigerant Safety Data Sheets.....	30

## 1. SAFETY CONSIDERATIONS

### IMPORTANT SAFETY NOTE

It takes only 5 seconds of skin contact with 140°F water to cause a second degree burn! You must protect against high water temperatures in all lavatories, tubs, showers and other points of hot water contact.

Accidental scalding from hot water is a greater risk in some types of installations. Some examples are:

- Homes For The Mentally Handicapped
- Homes For The Physically Handicapped
- Hospitals And Nursing Homes
- Elder Care Facilities And Rest Homes
- Orphanages And Child Care Facilities
- Potable hot water should be tempered to no more than 110°F when used for bathing or other personal uses in any installation where response to contact with hot water may be slower or where the danger of hot water contact is greater.

#### IMPORTANT!

Always follow local code requirements and the authorities having jurisdiction.

Thermostatically controlled mixing valves must be used in the design of the potable hot water system.

Good engineering practice mandates thermostatically controlled mixing valves set at 120°F or less to keep the delivered water temperature below scalding temperatures.

If the information in this manual is not followed exactly, a fire, explosion or exposure to hazardous materials may result, causing property damage, personal injury or death.

#### FOR YOUR SAFETY

Do not store or use gasoline or other flammable liquids near this or any other appliance.

#### WARNING!

If the information in these instructions is not followed exactly, a fire or explosion may result causing property damage, personal injury or death. Do not store or use gasoline or other flammable vapors and liquids in the vicinity of this or any other appliance.

#### WARNING!

Installation and service must be performed by a qualified installer, or service agency who must read and follow the supplied instructions before installing, servicing or removing the unit.

Refer to the information in this manual. Improper installation, adjustment, alteration, service or maintenance can cause property damage, personal injury, exposure to hazardous materials or death. Do not use matches, candles, flames, or other sources of ignition to check for gas leaks.

Fluids under pressure may cause injury to personnel or damage to equipment when released.

Be sure to shut off all incoming and outgoing water shutoff valves and carefully decrease all trapped pressures to zero before performing maintenance.

The electrical connection cover must be installed at all times, except during maintenance.

A disconnect switch must be installed at the electrical service connection per local codes.

**IMPORTANT:**

This manual contains information required for installation, operation and maintenance of the Lync AEGIS. Read and follow the information in this and all other provided instructions, labels and markings before installing, operating or servicing this equipment.

**1.1. General Warnings**

Read before proceeding any further in the manual.

- This manual is an integral part of the product and must be kept for consultation.
- The controller must not be used with functions other than those described herein.
- Before continuing, check the application limits.
- The company reserves the right to change the composition of its products without notice.

**1.2. Safety Precautions**

- Use the controller only within the intended operating limits.
- The electrical panel must not be opened by unauthorized personnel.
- Make sure cables for the probes and the power supply kept separate without twisting.

For applications in especially critical industrial environments, it may be useful to use network filters.

**CAUTION!**

Disconnect all electrical connections before starting any maintenance work.

## 2. INTRODUCTION

Aegis is a highly efficient, commercial heat pump solution that uses electricity and natural refrigerant-grade CO2 to produce domestic hot water up to 185°F all year round.

Using electricity and the superior qualities of R744, a natural refrigerant-grade CO2, the Aegis heat pump water heaters are one of the cleanest, most efficient and environmentally friendly ways to heat domestic water.

### 2.1. Aegis Models

Aegis comes in two versions: Aegis A and Aegis W. Aegis A absorbs and moves heat from the surrounding air at temperatures as low as -4°F to produce hot water. Aegis W produces hot water by absorbing and moving heat from a connected water source at temperatures as low as 14°F.

The model, serial number, power voltage, etc. are shown on labels affixed to the machine.

<b>LOGO</b>		<b>CE</b>
Modello/Model Modell/Modèle		
Tipo refrigerante Refrigerant type Kältemitteltyp Type réfrigérant	IP quadro elettrico IP electrical panel IP Schaltschrank IP tableau électrique	Matricola Serial number Seriennummer Matricule
Corrente massima assorbita Max. absorbed current Max. Stromaufnahme Courant maxi absorbée	Corrente massima di spunto Max starting current Max. Anlaufstrom Courant maxi de démarrage	
Tensione-Fasi-Frequenza Voltage-Phase-Frequency Spannung-Phasen-Frequenz Tension-Phase-Fréquence	Tensione circuiti ausiliari Auxiliary circuit voltage Steuerspannung Tension circuits auxiliaires	
Numero circuiti refrigerante Refrigerant circuit number Anzahl der Kältekreise Nombre circuits réfrigérant	Press. max refriger. alta/bassa Max. Refrig. pressure high/low Max. Nim Kältemittelbetriebsdruck Pression maxi réfrig. haute/basse	
Press. massima circuito idraulico Max. hydraulic circuit pressure Max. zulässiger Druck im Wassersystem Press. Maxi circuit hydraulique	Data di produzione Date of manufacture Herstellungstatum Date de production	
Carica refrigerante per circuito(kg)/Refrigerant charge per circuit(kg) Kältemittel Füllmenge je Kreislauf (kg)/Charge réfrigérant par circuit(kg)		
C1	C2	C3
		C4

<b>LOGO</b>	<b>CE</b>
MODELLO - MODELE - MODEL - TYP	
MATICOLA - MATRICULE - SERIAL NO. - SERIENNUMER	
REFRIGERANTE - REFRIGERANT - KÄLTEMITTEL - REFRIGERANT	

### 2.2. Unit Control

The unit control software is responsible for regulating the outlet water temperature from the appliance. The parameter displayed as "ST01 Set Hot Water" is user adjustable.

Additionally, the unit control manages the circulation of water in order to ensure that the correct temperature rise in the system is maintained and will determine the need for hot water recovery by monitoring the water temperature in the storage tanks.

Please note that the delivery temperature is regulated by modulating the pump, therefore the flow of hot water at the outlet is not constant.

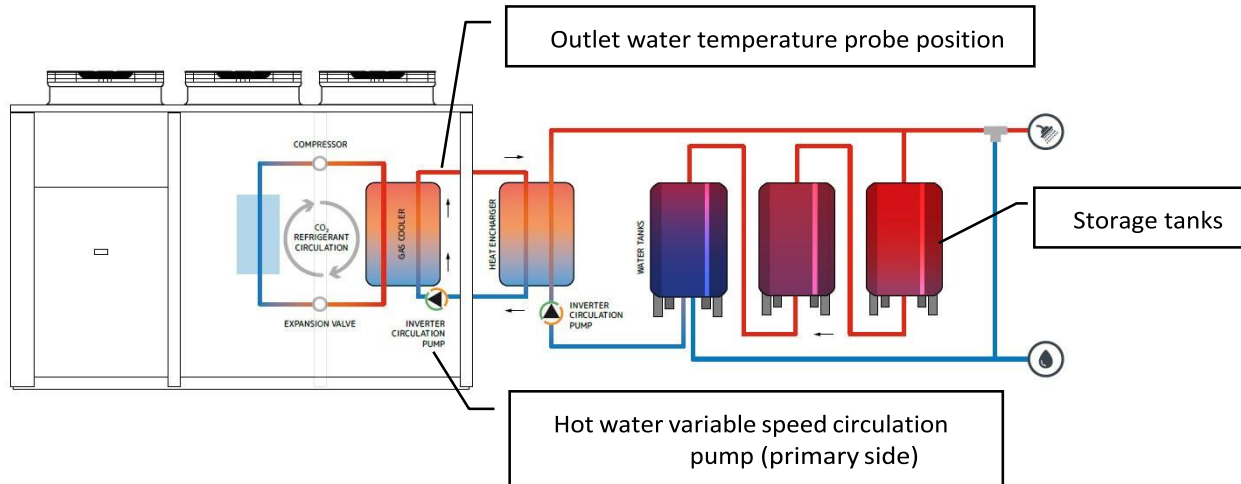

### 2.3. Sequence Of Operation

The hot water storage tanks used in this heating system must be equipped with the two provided temperature sensors, or other sensors meeting requirements for a NTC 10k temperature sensor. The BT2 sensor (hot side probe) is located in the top of the last storage tank in the series, near the supply outlet. The (BT1) sensor (cold side probe) is placed in the bottom of the first storage, near cold return water connection.

The optional BT3 sensor is located on the outlet of the external heat exchanger (see dedicated section) and is needed to modulate the inverter circulation pump placed between the heat exchanger and the storage tanks. Installation of BT1, BT2, and BT3 probes must be done by the installer prior to operation.

Note that the tanks must necessarily be hydraulically connected in series as shown below, not in parallel.

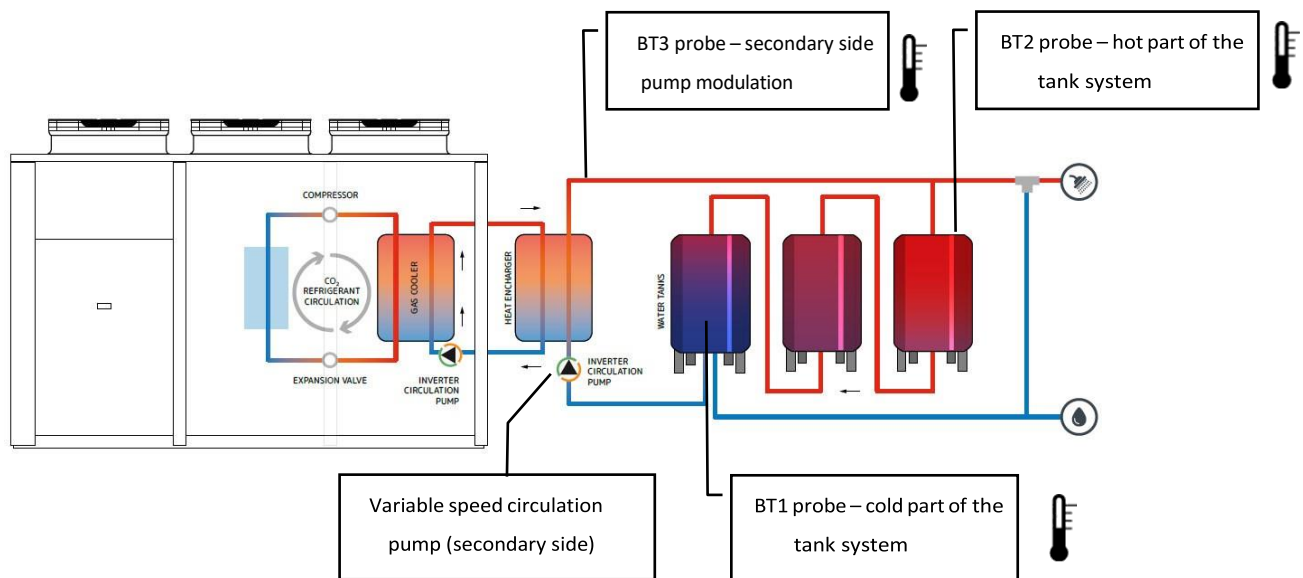

When the temperature probe BT1 reaches the value "Set point unit ON", (set point (ST03) minus differential (ST04)), the unit will be turned on. The unit will continue to heat the water to the set temperature as long as the temperature BT1 remains below the "Set point unit OFF" value (ST03). Once BT1 reaches "Set point unit OFF" the unit will be turned off.

To limit the possible discomfort that can be generated by excessive heat dissipation, or excessive and rapid spillage of water from the top of the tanks, you can use the probe BT2 to operate a "comfort" function. In this case, even if the temperature BT1 is higher than the value of "Set point unit OFF", the unit operate when the BT2 is lower than a value of "Set point comfort ON".

Operation with only the BT1 probe is allowed, while the use of the BT2 probe requires the presence of the BT1 probe. The unit will turn off only when both the BT1 and BT2 temperatures are greater than the related set points.

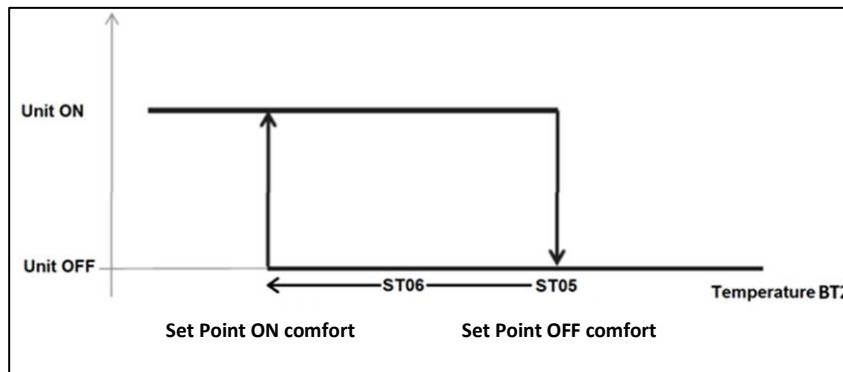

### IMPORTANT

The unit will begin to run with only the BT1 probe, regardless of BT2 probe. If the unit runs based on the BT2 probe, regulation with BT1 probe will also start automatically, even if the starting parameter (ST02) is OFF.

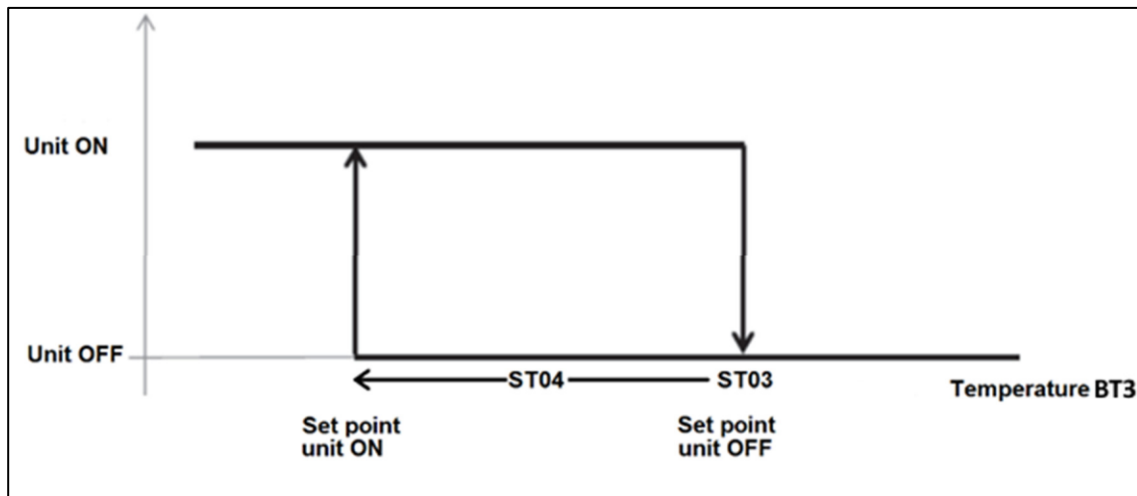

Please refer to Aegis Electronic Controller Manual (L-OMM-013) for information on enabling and choosing between local analog and remote digital input.

## 2.4. Version With Cool Recovery (Air Source Unit Only)

Using the cool recovery option, heat can be drawn from a water stream rather than the ambient air, thus providing cooling to a water loop. This can be used to not only increase the performance of the heat pump, but also increase the performance of water loops such as a central chilled water system. See Aegis Electronic Controller Manual (L-OMM-013) for further details on how to activate and control this function. NOTE: This option is available only for the Air source unit.



## 2.5. Domestic Hot Pump Management

The software also manages the domestic hot water pump. The start, minimum and maximum speed can be adjusted separately for both pumps. The domestic hot water pump can be active when the unit is in standby, but this setting is strongly not recommended, to avoid the destratification of the temperature in the tanks.

Please note that the main unit pump and the domestic hot water pump operate with coordinated set points in the sense that an offset (that can be set by the user) is subtracted from the unit set point ST1 and it is used to regulate the domestic hot water pump referred to the BT3 probe. It is needed to apply a regulation offset (it must be negative) to adjust the secondary pump set point to take in consideration the temperature losses in the plate exchanger.

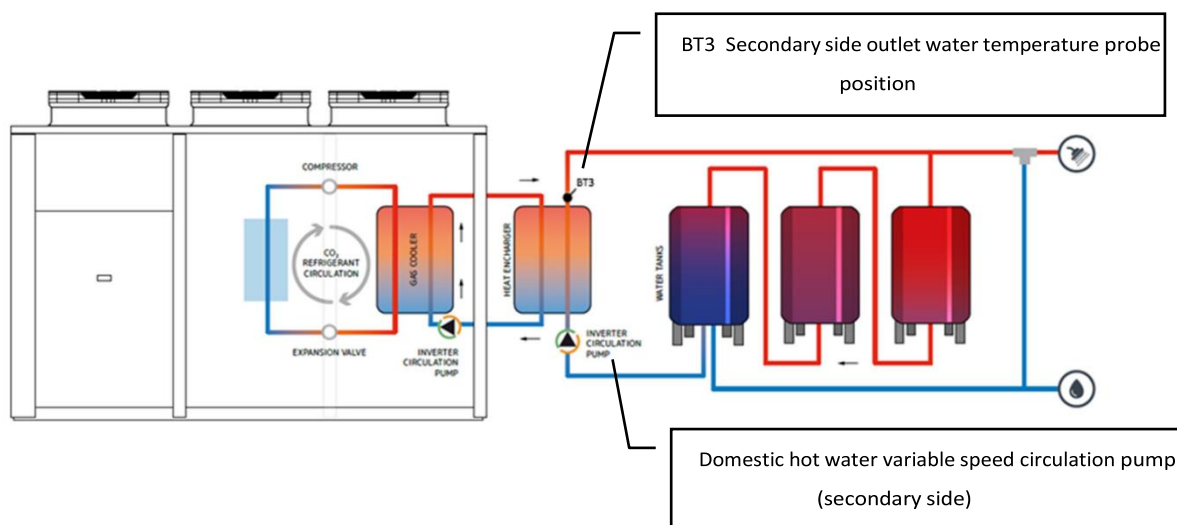
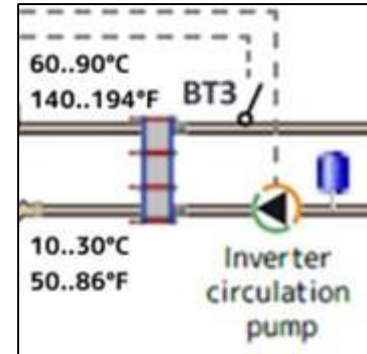

**NOTE:** Speed regulation of the secondary side pump is independent from regulation of the internal pump. Please see Aegis Electronic Controller Manual (L-OMM-013) for details.

## 2.6. Superheat Set Limit

For inlet water temperature  $> 30\text{ }^{\circ}\text{C}$  ( $>86\text{ }^{\circ}\text{F}$ ) the superheating is managed by 3-way bypass valve in combination to specific software improvements. The High Inlet Temperature (HIT) Function limits the superheat value with the use of the bypass valve, keeping in consideration both the compressor oil temperature and the compressor discharge temperature.

In order to optimize the cycle efficiency and at the same time avoid too high temperatures to the compressor, the target superheat value is not constant, but will be adjusted according to the compressor discharge temperature and compressor oil temperature.

This superheat limit should not be changed by a user except under direction from the manufacturer or an authorized manufacturer's representative.

## 2.7. High Inlet Temperature (Hit) Function

The HIT function allows the heat pump to operate even with inlet water temperatures above the standard limits. It is utilized:

- for the anti-Legionella treatment (tank temperature > 60 °C (>140°F), see below)
- when domestic water recirculation is used with low water demand
- when heat pump stops for a long time and the tank thermally stratifies.

## 2.8. High Pressure Set Point Calculation

The high pressure set point is not fixed, but instead is calculated based on inlet water temperature, outlet water temperature, and evaporation temperature. The pressure is managed by the thermostatic valve.

The setpoint value is limited between a minimum and a maximum fixed value. Within these limit values is also active a compensation curve based on the evaporator temperature that keeps the compressor within the required operating envelope.

## 2.9. Anti-Legionella

Legionellosis is an infection caused by aerobic bacteria of the genus Legionella that mainly affects the respiratory system. The name of the disease derives from the fact that the bacterium was first identified in 1976 on a group of participants in a gathering of the American Legion in a Philadelphia hotel, on that occasion 291 people contracted the disease and 34 of them died.

The proliferation of Legionella depends on the water temperature. As can be seen from the chart below, the disinfection is feasible through thermal shock.

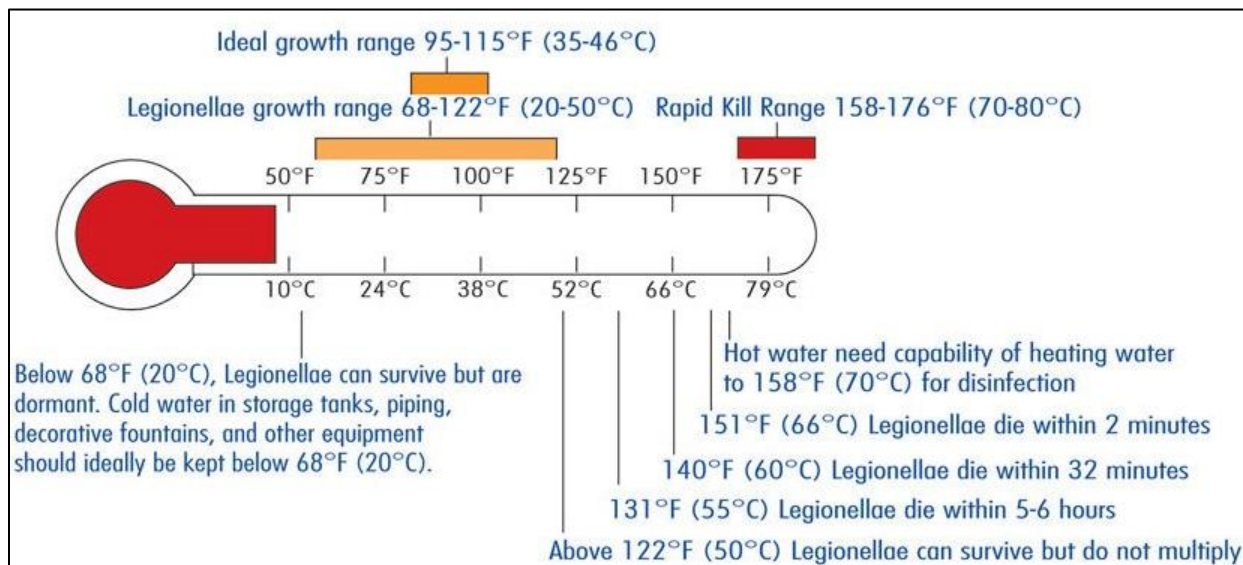

**Figure 1: Legionella Growth Chart<sup>1</sup>**

The anti-Legionella function consists in bringing the water storage tanks to a high temperature and subsequently carrying out a recirculation to ensure complete disinfection of the system.

<sup>1</sup> Freije, Matthew R. *How to Make Plumbing Systems Less Conducive to Legionella and Other Bacteria*. HC Information Resources, 1998. .

The anti-Legionella function, if enabled via “ALG01 Enable anti-Legionella” is activated based on a time band (if “ALG02 Enable scheduler” is set) or manually via web interface / BMS (“ALG16 Manual start” and “ALG17 Manual stop”).

More in detail, the conditions necessary to make the anti-Legionella function activable are:

- HP90 unit active (Unit ON)
- anti-Legionella function enabled (parameter ALG01 set to ON)
- no BTL probe alarm
- no BT1 probe alarm
- absence of expansion # 1 offline alarm
- absence of expansion # 2 offline alarm

The anti-Legionella cycle consists of two phases - it is emphasized that in phase 1 the compressor is active, and the pump modulates as per standard thermoregulation (on “ALG10 Unit anti-Legionella set”), while in phase 2 the compressor is inactive, and the pump forced to default speed (on “ALG11 Unit phase 2 pump set”):

### 2.1.1. Phase 1

The "Anti-Legionella active" relay contact is closed.

The set point “ALG10 Anti-Legionella unit set” is forced (e.g.176-194°F [80-90 ° C]);

Phase 1 ends when the BT1 probe rises above “ALG08 Phase 1 set BT1” (default = 140°F [60 ° C]) and at the same time the BTL probe reaches at least the “ALG09 Phase 1 set BTL” (default = 131°F [55 ° C]).

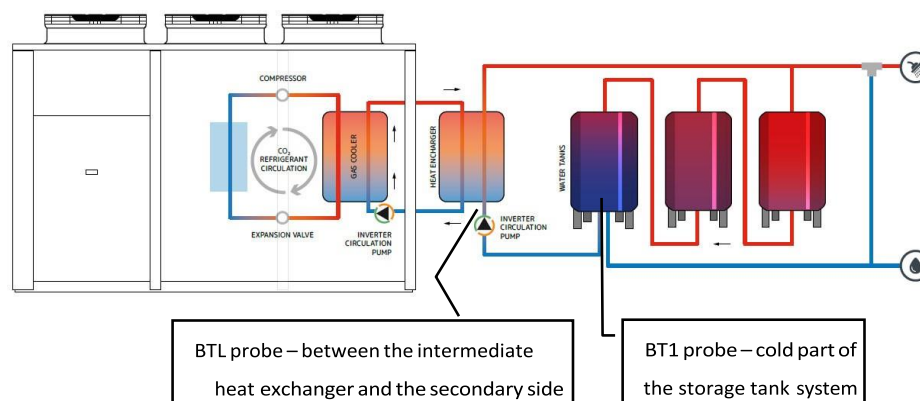

### 2.1.2. Phase 2

1. The "Anti-Legionella active" relay contact remains closed
2. The "Anti-Legionella phase 1 completed" relay contact is closed
3. At the end of phase 1 the compressor switches off while the secondary pump is brought to a fixed speed “ALG11 Unit phase 2 pump set” until the BTL probe reaches the “ALG09 Phase 2 set BTL” (e.g. 70 ° C). The anti-Legionella cycle is considered concluded when this condition persists for a period of time “ALG12 Min. time phase 2” (e.g. 1 min).
4. At the end of the cycle, the "Anti-Legionella active" and "Anti-Legionella phase 1 completed" relay contacts are opened.

**NOTE:** The maximum time parameter of the anti-Legionella cycle “ALG06 Anti-Legionella max time” is provided (e.g. 120 min.) after which the unit returns to normal operation.

The Defrost function has priority over the anti-Legionella function.

### 3. INSTALLATION

The Aegis A is an air source model certified for indoor or outdoor installation. It should be installed outdoors wherever possible, and with the maximum available space for air intake and maintenance. A minimum of 9 ft (3 m) of overhead clearance is required to prevent the possible recirculation of air between intake and exhaust. The Aegis W is intended for indoor installation.

The following must be taken into account when choosing the unit's place of installation and making the relative connections:

- size and origin of the hydraulic piping;
- location of the power supply;
- accessibility for maintenance or repair operations;
- solidity of the support surface;
- ventilation of the air-cooled condenser;
- orientation and exposure to solar radiation: keep the condensing coil out of direct sunlight whenever possible;
- do not position the unit in a way that strong winds favor air recirculation at the condensing coil;
- do not position the machine on dark colored land (e.g. tarred surfaces) so as not to cause functioning overheating;
- possible sound reverberation

It is obligatory to observe the clearances specified in the dimensional drawing of the unit. The unit must always be anchored to the ground.

Provide a solid base on which to position the unit. This support must be flat and horizontal with dimensions suitable for the unit, especially if the unit is to be positioned on unstable ground.

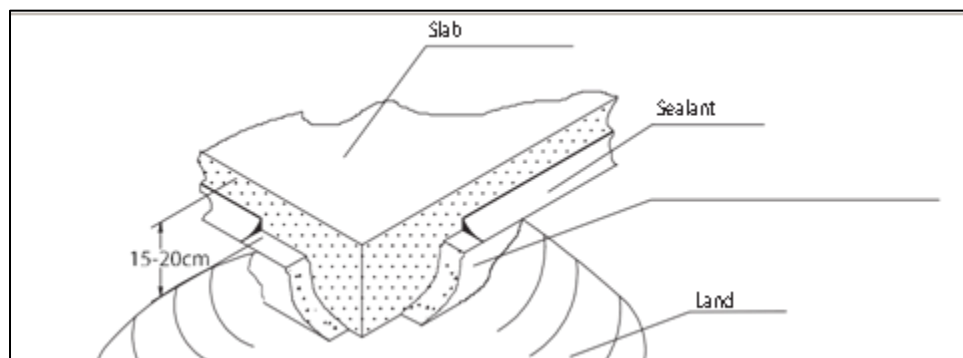

**Figure 2: Structure Of A Typical Support Slab**

The slab should be in suitable foundation with a height of about 6-8 inches (15-20 cm) above the surrounding land and at least 12 inches (30 cm) longer and wider than the machine.

Although the unit transmits low levels of vibrations to the supporting structure, it is recommended to lay a sheet of hard rubber between the base of the unit and the supporting surface. If better vibration isolation is required, beyond the included anti-vibration supports, contact a certified seismic engineer. In the event of installation on roofs or intermediate floors, the unit and the piping must be isolated from the walls and ceilings.

The units should not be positioned in proximity of private offices, bedrooms or areas where low sound emissions are required. To prevent excessive sound reverberation, do not install the unit in narrow or confined spaces. For noise levels in specific operating conditions, please see the Aegis Technical Data Sheet or contact your local Lync rep.

The machine equipped with standard coils should not be installed in a corrosive environment. Particular care should be taken to avoid atmospheres containing sodium chloride, which can aggravate corrosion due to galvanic currents; a machine with untreated coils must not, for any reason, be installed in a marine environment unless provided with the optional coil coating for coastal areas.

In the case of a marine or highly polluting industrial environment, it is necessary to request coils with anti-corrosion surface treatment.

If there are any questions about applicability for a particular environment, contact your local Lync representative.

### 3.1. Spaces For Installation

The service spaces to comply with are shown on dimensional drawings AP-A-1058, -1059, and -1060, available at [lyncbywatts.com](http://lyncbywatts.com).

The evaporating coil must be allowed adequate space for the airflow at both the intake and the exhaust side. In order to prevent poor unit capacity or even interruptions in unit operation it is absolutely essential to avoid the recirculation of air between the intake and the exhaust.

High walls near the unit may interfere with its proper functioning. Units should be installed a minimum of 9 feet (3 meters) apart.

It is advisable to leave sufficient space between the units for removing their larger components such as the exchangers, compressors or pumps.

### 3.2. Anti-Vibration Mounts

In order to reduce vibrations transmitted to the structure, it is recommended to install the machine on rubber or spring anti-vibration mounts, supplied as an accessory.

The dimensional layout attached to the machine shows the position and load of each antivibration mount. The anti-vibration mounts must be applied before positioning the machine on the ground.

#### 3.2.1. Rubber Anti-Vibration Mounts

The anti-vibration mount consists of an upper metal bell with a screw to fasten the unit base. The antivibration mount is fastened to the base through the two holes on the flange. The anti-vibration flange bears a number (45,60,70 Shore A) that identifies the hardness of the rubber support. The Aegis 250 A has (4) 60° Shore A mounts, the Aegis 350-500 A has (2) 60° and (4) 75° mounts, and the Aegis W 250-500 have (4) 75° mounts.

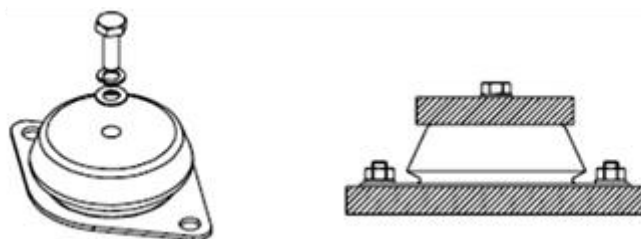

### 3.3. General Recommendations For Hydraulic Connections

#### **WARNING!**

The units may produce hot water at temperatures as high as 194°F (90°C). All hydronic components must be selected for this temperature.

When setting up the hydraulic circuit for the gas cooler, it is good practice to comply with the following prescriptions and with the national and local regulations. It is recommended to connect the piping to the heat pumps using flexible joints in order to prevent transmission of the vibrations and compensate for thermal expansion.

Install the following components on the piping:

- Stop cocks, temperature and pressure indicators for maintenance and unit inspection.
- Sample points on the input and output pipes to read the temperature, if temperature indicators are not present.
- Shut-off valves to isolate the unit from the hydraulic circuit.
- Metal mesh filter with openings not wider than 1/16" (1 mm) on the exchanger inlet pipe to protect the exchanger against slag or impurities in the pipes.
- Air vents installed at the highest parts of the hydraulic circuit in order to allow excess air to be released.
- Expansion tank and automatic charging valve for maintenance of the system pressure and to compensate for thermal expansion.
- Drain valve and where necessary, drain tank to empty the system for maintenance operations or seasonal breaks.

#### **IMPORTANT**

It is highly recommended to install a safety relief valve on the hydraulic circuit. If serious anomalies should arise in the system (e.g. a fire breaks out), this allows the system to be drained to prevent an explosion. Always connect the drain to a pipe with a diameter no less than that of the valve opening and direct it towards the areas where the discharge cannot harm anyone.

### 3.3.1. Recommended Hydraulic Circuit

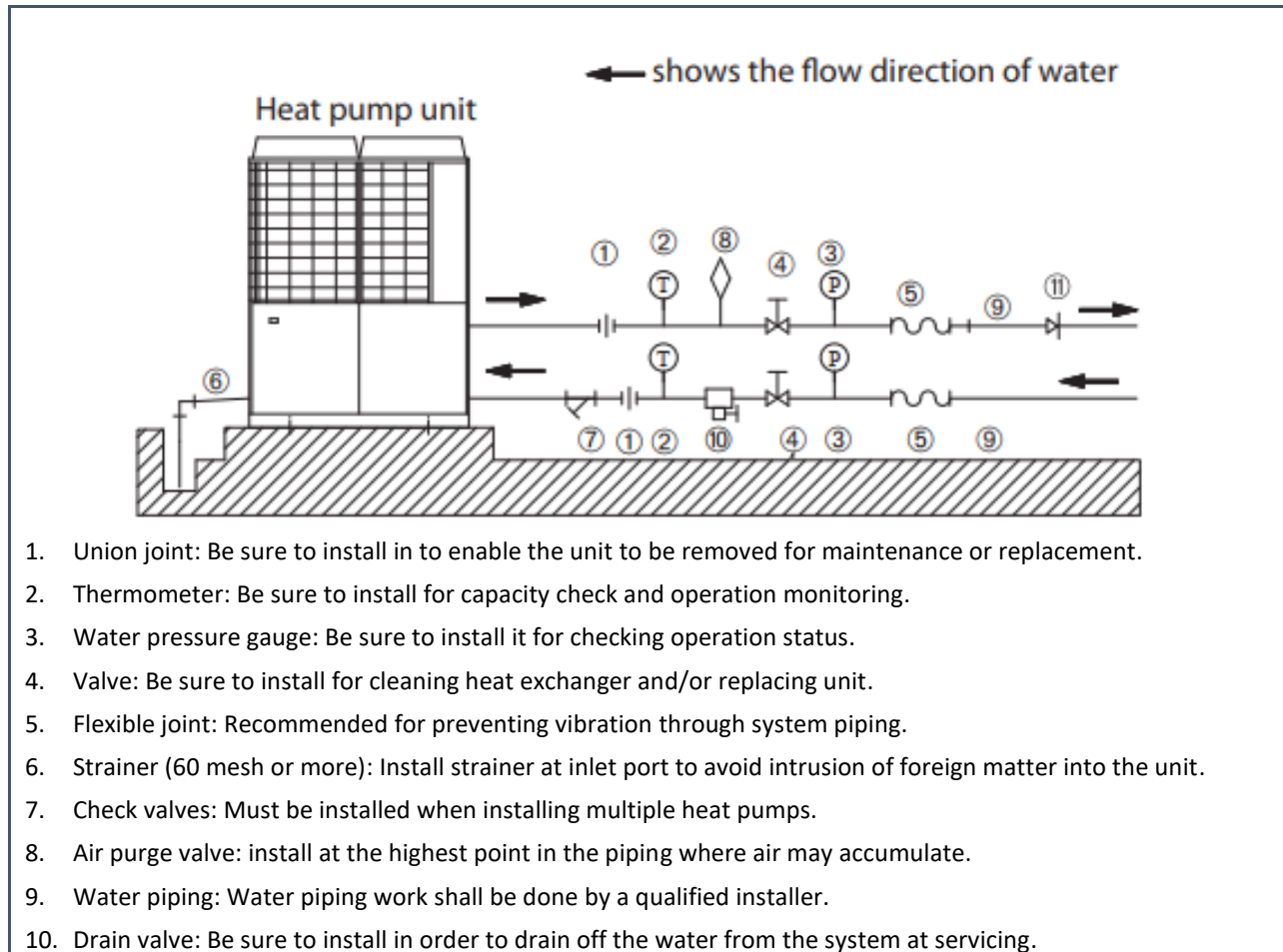

**Figure 3: Recommended Water Piping**

### 3.3.2. Key Considerations For Water Piping

**Water quality:** It is important to check in advance whether the feed water and hot water have good quality. Be sure to use water within the ranges specified in Section 4.3

**Foreign matter in water:** If solid matter such as sand piping debris, scale deposits, and/or floating suspended solids such as corrosion product exist in water, the heat-transfer surface of heat exchanger is directly attacked by water flow, and corrosion may be created locally. In order to avoid such corrosion by these foreign matters, be sure to fit a cleanable strainer (60 mesh /0.25mm or smaller) at the water inlet port of the unit to remove foreign matters.

**Contact of dissimilar metals:** Depending on the type of metal, certain metals when placed in contact with each other may cause localized corrosion. Special measures should be taken to limit corrosion, such as the inclusion of non-conductive materials in between metals.

Water piping should have no leaks or air intrusion. If air is introduced at the suction side of pumps, the pump may create excess noise and performance may decrease.

For installations exposed to freezing temperatures, take precautions to prevent the freezing of piping. Note: Aegis A has a freeze protection function, Aegis W does not. In either case it is recommended to include a proper glycol mixture in the primary loop in the case of power loss. Contact your glycol supplier for further details on freeze protection.



### 3.4. Lifting And Transport

While unloading and positioning the unit, take extreme care to avoid sudden, violent movements. Avoid applying force to components of the machine. The unit may be lifted using assistance from a forklift, inserting the lifting forks in the lifting pallet (see Figure 4).

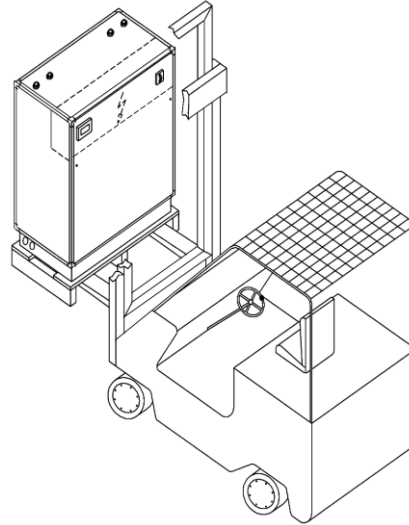

**Figure 4: Lifting the Unit with Forklift**

### 3.5. Removing Transportation Braces

During transport, the unit may be subjected to strong vibrations. To ensure no damage occurs as a result, transport braces were fitted prior to transport. When the unit arrives, it is necessary to remove these from the unit and the pallet.

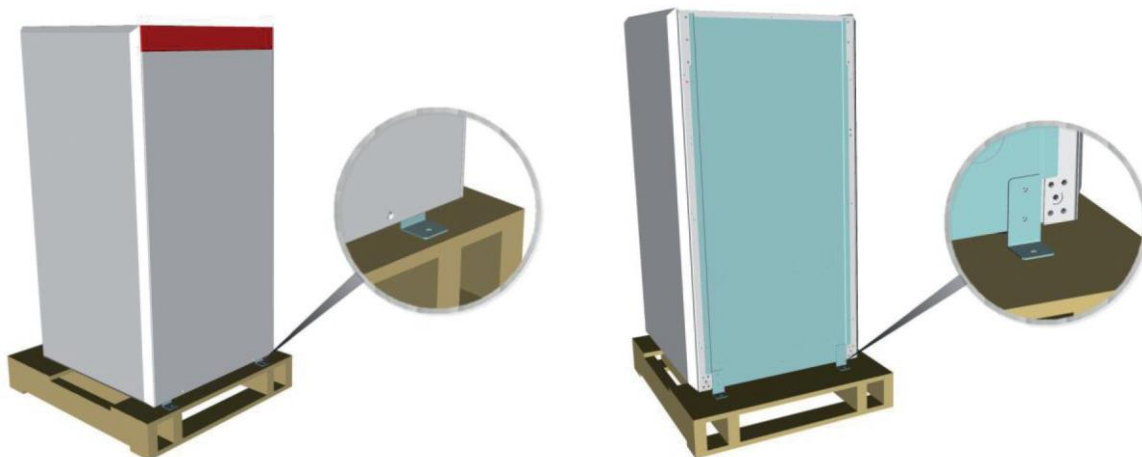

**Figure 5: Transport Brace Locations**

#### **IMPORTANT**

After the unit has been positioned it is necessary to remove the transportation screws between the wooden pallet and the damping platform. The screws are indicated within the unit with appropriate labels. The number of braces depends on the size of the unit.



*Figure 6: Transport Screw Locations*

### 3.6. Lifting And Transport (Aegis A Air To Water Units)

During unloading and positioning of the unit, great care must be given to prevent sudden or violent maneuvers and not using machine components as lifting points.

Lift the unit using steel tubes inserted in the relative lifting holes. Use cords or belts that are long enough and spacer bars so as not to damage the sides and lid of the unit.

**Note:** Pipes must have passages, pivots, or other fasteners to prevent straps from releasing.

Alternatively, the units can be lifted using a fork-lift truck, inserting the forks in the supporting pallet. The figure below illustrates typical lifting modes; take a look at the dimensional drawing for a clear identification of the center of gravity.

#### **WARNING!**

Make sure that the unit is fastened well before lifting in order to prevent accidental falls or overturning.

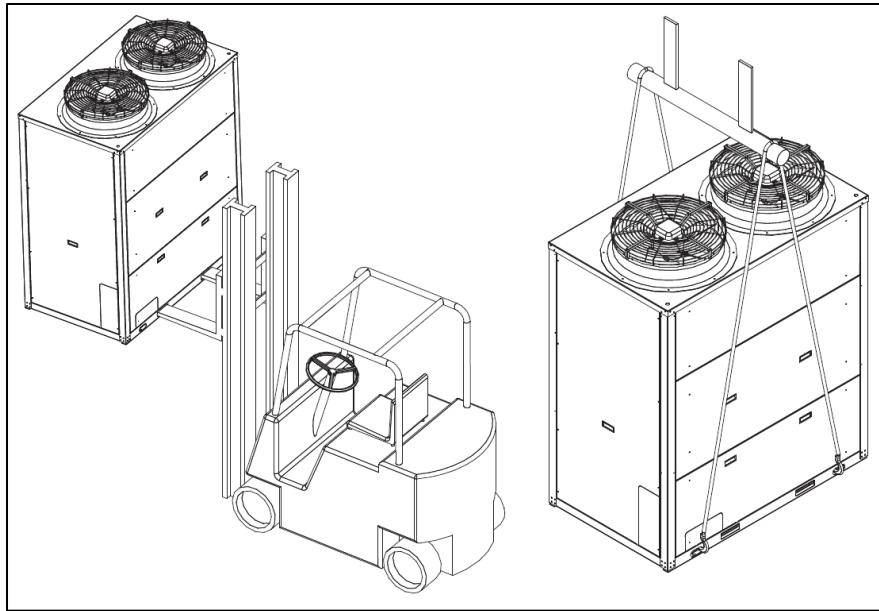

**Figure 7: Typical Lifting Modes**

**WARNING:**

The pictures may appear different than your actual unit. All images in this manual are for explanation purpose only; all information and reference to lifting applies to all of our models.

## 4. HYDRAULIC CONNECTION

### 4.1. Hydraulic Connection To The Exchanger

#### IMPORTANT

The water inlet must be installed where the connection is marked with the following plate:

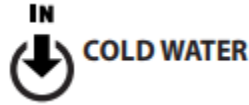

#### IMPORTANT

The primary circuit should be set up in such a way as to guarantee a constant flow of water to the exchanger in all operating conditions. If this is not the case, there is a risk of refrigerant returning in the liquid state to the compressor input which could damage the compressor.

#### WARNING!

Do not operate hydraulic connections with open flame near or inside the unit.

#### IMPORTANT

To ensure the correct operation of each pump on the machine:

- Before starting check that the pump shaft rotates freely, without mechanical impediments.
- Do NOT run the pump dry, unprimed and below the minimum nominal water flow rate.
- Do NOT operate the pump with closed shut-off valves, suction side and delivery side.
- It is forbidden to use the pump in case of cavitation.
- It is mandatory to fill and bleed the hydraulic circuit correctly before starting the pump.

### 4.2. Minimum Source Water Content In The Plant

For water source units or air source with cool recovery, it is important to maintain a minimum water volume in the source loop to ensure sufficient compressor runtime. The compressors can run intermittently; this is because the amount of heat power required by the system is not generally the same as that provided by the machine.

The formula below is for calculating the minimum water content on the source loop. If the actual pipe volume is less than required, a buffer tank is required.

$$V_{min} \geq P_{tot} \times 50$$

$V_{min}$  : water content of tank [l]

$P_{tot}$  : power capacity of the unit [kW]

**NOTE:** This formula is for the volume of storage for cold source water on W models or A models equipped with cool recovery option.

Buffer tanks must be properly insulated to prevent condensation and to not have an adverse effect on system performance.

### 4.3. Water Composition

Dissolved substances in the water can cause damage to the heat exchangers. It is mandatory to verify that the water parameters comply with this table:

Total hardness	2.0 to 6.0 °F
Langelier index	- 0.4 to + 0.4
pH	7.5 to 8.5
Electrical conductivity	10 to 500 QS/cm
Organic element	-
Hydrogen carbonate (HCO <sub>3</sub> <sup>-</sup> )	70 to 300 ppm
Sulphates (SO <sub>4</sub> <sup>2-</sup> )	< 50 ppm
Hydrogen carbonate / Sulphates (HCO <sub>3</sub> <sup>-</sup> /SO <sub>4</sub> <sup>2-</sup> )	> 1
Chlorides (Cl <sup>-</sup> )	< 50 ppm
Nitrates (NO <sub>3</sub> <sup>-</sup> )	< 50 ppm
Sulphuric acid (H <sub>2</sub> S)	< 0.05 ppm
Ammonia (NH <sub>3</sub> )	< 0.05 ppm
Sulphites (SO <sub>3</sub> ), free chlorine (Cl <sub>2</sub> )	< 1 ppm
Carbon dioxide (CO <sub>2</sub> )	< 5 ppm
Metal cations	< 0.2 ppm
Manganese ions (Mn <sup>++</sup> )	< 0.1 ppm
Iron ions (Fe <sup>2+</sup> , Fe <sup>3+</sup> )	< 0.2 ppm
Iron + Manganese	< 0.5 ppm
Phosphates (PO <sub>4</sub> <sup>3-</sup> )	< 2 ppm
Oxygen	< 0.1 ppm

If water is used that does not meet the criteria in the table, the warranty is immediately rendered null and void.

It is mandatory to set up a system that eliminates the possible organic substances in the water that could pass through the filter and settle in the heat exchangers, which would lead to malfunction and/ or damage over time.

If the water used in the unit contains organic substances, the warranty is immediately rendered null and void.

### 4.4. Discharge of Safety Valves

#### **WARNING!**

To avoid personal injury and property damage due to valve operation, the safety valve must be installed so that any discharge runs to a safe place of disposal. Consult with your local plumbing codes and standards for any additional requirements.

#### 4.5. Condensate Disposal

The Aegis A is equipped with two condensate drain pipes per air coil (2 for Aegis A 250, 4 for Aegis A 350-500). This allows for the proper disposal of condensate after a defrost cycle. This condensate must be piped to a drain. In the case of freezing conditions, condensate piping must be insulated and/or wrapped with a heating coil to prevent condensate freezing in the piping.

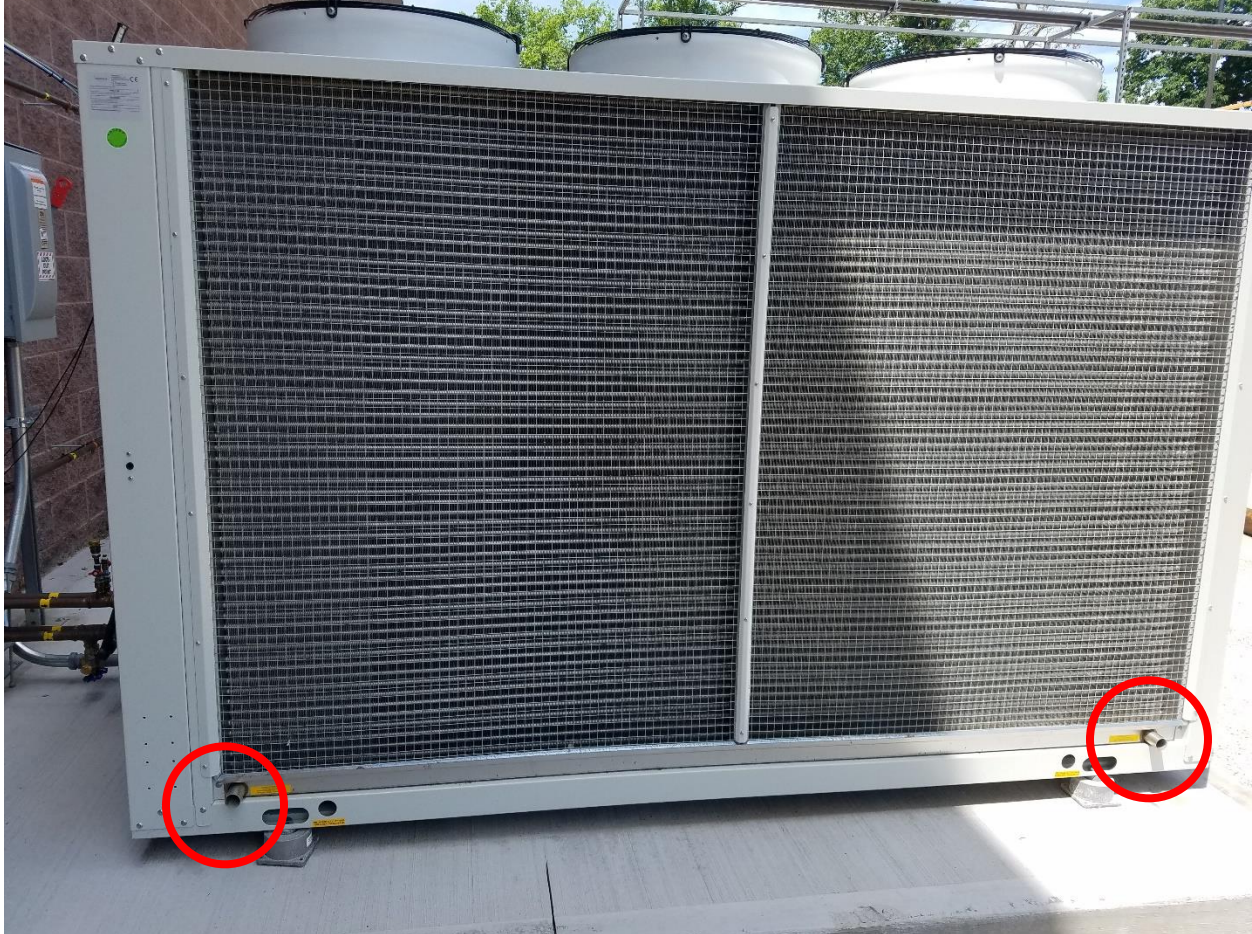

**Figure 8: Condensate Drain Pipes**

## 5. ELECTRIC CONNECTIONS

### 5.1. Overview

- The electrical connections must comply with the information shown on the wiring diagram attached to the unit and the regulations in force in the place of installation.
- The installer must connect the grounding cable using the relevant PE clamp on the earth bar situated in the electric control board.
- Verify that the power supply voltage corresponds to the nominal data of the unit (voltage, number of phases, frequency) stated on the plate on the machine.
- The power supply voltage must not undergo variations over  $\pm 5\%$  and the unbalance between the phases must always be less than 2%.
- Check that the line is connected with the correct phase sequence.
- To feed in the electrical cables, use the phase sequence. The power cord is fed through the bottom part of the electric control board.
- The control circuit power supply derives from the power line via a transformer situated in the electric control board. The control circuit is protected by relevant fuses.

#### IMPORTANT

Use power cable fixing systems that resist abrasion and twisting stress.

Make sure there is no voltage present before performing any operation on electric parts.

The section of the cable and the line protections must comply with that indicated in the wiring diagram and the relevant table attached to the unit.

The resistances must be powered at least 12 hours before the initial startup during cold weather conditions to allow the compressor oil to come up to temperature, and takes place automatically when the master switch is closed. In warmer conditions this time may be shorter.

The unit must operate with those limits; failure to do so will immediately void the warranty.

### 5.2. Fan Speed Controller

The unit comes equipped standard with a fan speed control device. This enables the unit to operate at elevated ambient air temperatures by reducing the air flow rate to the evaporator and remain within the operating envelope.

This device can also be used to reduce the sound emissions of the unit when the external air temperature tends to decrease (e.g. during the night).

This control is calibrated and inspected in the factory.

If further fan speed control is required, or higher pressures are required for ducting the unit exhaust, electrically commutated (EC) fans are available as a factory option.

#### WARNING

Do not modify speed control calibrations. If this is required, please contact the manufacturer.

### 5.3. Powering The Crankcase Heater

In order to ensure optimal oil temperature on startup, the compressor is equipped with a crankcase heater and oil temperature sensor. To power this heater:

- Check direction of fan to make sure the phase sequence is correct (fans should be drawing air into the unit and exhausting colder air out through the top of the unit.). If the coils have air coming out instead of in then the phases are wrong and two legs should be swapped.
- Close the main switch by turning it from OFF to ON
- Check that “OFF” appears on the display
- Make sure the unit domestic hot water demand is “OFF” and that the external enable/disable contact is open
- Leave the machine in these conditions for at least 12 hours to power the crankcase heater.

### 5.4. Potential Free Contacts

The following potential free contacts are available:

- 1 contact for the alarm relay
- 1 dry contact for compressor status
- 1 dry contact for enabling the domestic hot water pump

### 5.5. Controller Function

Refer to the Lync Aegis Controller Manual L-OMM-013, supplied separately.



## 6. STARTUP

### WARNING!

The machine should be started up only by authorized and qualified personnel.

### 6.1. Preliminary Verifications

- Check that the electrical connection has been implemented correctly and that all clamps are tightly fastened.
- Check that the voltage on the RST clamps is  $460\text{ V} \pm 5\%$  (line voltage should show  $277\text{V} \pm 3\%$ ). If the voltage is subject to frequent variations, contact Lync technical services or your local rep for the selection of relevant protections.
- Check that the pressure in the refrigerant circuits is shown on the control display.
- Check for refrigerant fluid leaks by using a leak detector intended for R-744 refrigerant.
- Check the correct power supply of the guard resistances.

### WARNING

The resistances must be inserted at least 12 hours before the initial start-up and takes place automatically when the master switch is closed.

To check the correct functioning of the resistances, check that the lower part of the compressors is hot and in all cases is at a temperature of  $5\text{-}8^{\circ}\text{F}$  ( $10\text{-}15^{\circ}\text{C}$ ) over the environment temperature.

- Check that the hydraulic connections have been made correctly, respecting the indications on the input/output plates on the machine.
- Check that the hydraulic system has been bled, thereby eliminating all residual air and loaded gradually, opening the vent devices in the upper part, which the installer would have set up together with an expansion tank of adequate capacity.

### ATTENTION

Before starting-up, verify that all the closing panels of the unit are in place and secured.

### WARNING

All the units are pre-loaded with refrigerant gas, so the refrigerant circuit is pressurized. There is no need to charge the refrigerant circuit before unit start up.

### 6.2. Verifications During Operation

- Check that the sequence of the phases is correct. This can be verified by making sure that the fans are rotating in the correct direction (see Section 5.3). The fan should be pulling air in the side of the heat pump and directing it up out the top of the unit.
- Check that gas cooler inlet water temperature is near the electronic control setpoint.

## 7. CALIBRATING CONTROL COMPONENTS

### ATTENTION

The control equipment should be serviced by qualified and authorized staff only. Incorrect calibration settings can cause serious damage to the unit and injuries to people.

The control equipment is entirely calibrated and tested in the factory before the unit is shipped. However, after the unit has been working for a reasonable period of time, the safety devices should be checked. The calibration settings are shown in Table 2.

Control and safety components	Activation set point	Differential
Safety valve setting: high pressure side	1740 PSI [120 bar]	n/a
Safety valve setting: low pressure side	1160 PSI [80 bar]	n/a
High pressure switch setting	1566 PSI [108 bar]	1160 PSI [80 bar]
Low pressure switch setting	290 PSI [20 bar]	580 PSI [40 bar]
Anti-freeze alarm setting	39°F (4°C)	11°F (6°C)

## 8. DECOMMISSIONING

### 8.1. Seasonal Shutdown

- The Aegis heat pump water heater is designed for year-round operation. In the case that prolonged shutdown is expected, be sure to follow these steps
- Disconnect the voltage using the machine master switch/main isolating switch.
- Drain the hydraulic system (unless it contains glycol water).
- Repeat the procedure outlined in Section 6 on successive start-ups.

### 8.2. Emergency Stop

To stop in an emergency, turn OFF the main switch to power off the entire machine.

#### IMPORTANT

Never modify the internal electrical connections, otherwise the warranty is immediately rendered null and void.

Disconnect voltage from the unit only in the case of prolonged shutdowns, to leave the compressors guard heating resistances powered.

#### WARNING

Do not use the main power switch to enable or disable the heat pump: this device should be used to isolate the unit from the power supply when the unit is OFF. Removing voltage entirely depowers the guard resistances, jeopardizing the integrity of the compressor.

## 9. PERIODIC MAINTENANCE AND INSPECTIONS

#### WARNING

Before performing any service on the unit or accessing internal parts, make sure that the power supply has been disconnected.

The inverter of the compressor contains various parts that remain live for a few minutes after the power supply has been disconnected at the main switch.

Before any maintenance:

- turn off the machine at the main switch;
- wait at least 5 minutes;
- use a multimeter to make sure there is no voltage at the heads of the clamps;
- make sure the motor has completely stopped;
- check that the dissipator is not hot: contact with the dissipator can cause burns.

Pay special attention when operating near the finned coils as the aluminum fins are particularly sharp. The compressors, the flow pipes and the dissipator of the inverter are hot.

### 9.1. Overview

It is good practice to carry out periodic inspections to verify the proper operation of the unit:

OPERATION	FREQUENCY
Check functioning of all control and safety appliances as described previously	Monthly
Check the tightness of the electric terminals both in the power panel and in the compressors' terminal boards. The mobile and fixed contacts of the remote controls must be cleaned periodically and must be replaced whenever they show signs of deterioration.	Monthly
Verify that there are no oil leaks from the compressor	Monthly
Check there are no water or water/glycol mixture leaks in the hydraulic circuit	Monthly
If the unit is to remain out of service for a long period, drain the water from the pipes and the heat exchanger. This is necessary whenever room temperatures are lower than the freezing point of the fluid used throughout the standstill period.	Seasonal
Verify the filling of the water circuit	Monthly
Check the heater of the compressor guard	Monthly
Clean the metal filters in the hydraulic pipes	Monthly
Clean the finned battery and the metal filters, if present, using compressed air in the opposite direction to the passage of air. If it is clogged, use a jet of water taking care not to bend or damage the fins of the coil.	Monthly
Perform the defrosting test	Monthly
Verify the state, fastening and balance of the fans	4 months
Ensure that the noise emitted by the machine is regular	4 months
Clean the outlets of the condensate drip tray	Monthly

#### IMPORTANT

Routine maintenance of the unit is essential to the life of the machine. A lack of maintenance can cause malfunctioning and/or damage to the unit and render the warranty null and void.

### 9.2. Protection Of The Environment

The law regarding the regulations of use of stratospheric ozone depleting substances prohibits the dispersion of refrigerant gases in the environment and obliges holders to recover them and return them to the dealer or special collection centers at the end of their operational life.

#### IMPORTANT

Particular attention is recommended during maintenance to reduce refrigerant leaks.

## 10. DISPOSAL OF THE UNIT

When the unit has reached the end of its intended duration and must be removed and replaced, a number of measures must be taken:

- The lubricating oil of the compressors must be recovered and sent to collection centers.
- The unit's structure and components, if no longer usable, should be taken down and divided by type of material; this regards in particular copper and aluminum parts, of which there are fair amounts in the unit. This is to ease collection, disposal and recycling centers and minimize environmental impact.

## 11. REFRIGERANT

### 11.1. Refrigerant Safety Data Sheets

#### I. Identification Of The Substance/Mixture And Of The Company/Undertaking

1.1 Product identifier	Product name	Carbon dioxide EC No (from EINECS): 204-696-9 CAS No: 124-38-9 Index-Nr -
	Chemical formula	CO <sub>2</sub>
	REACH Registration number:	Listed in Annex IV/V of Regulation (EC) No 1907/2006 (REACH), exempted from registration
1.2. Relevant identified uses of the substance or mixture and uses advised against	Relevant identified uses	Industrial and professional Perform risk assessment prior to use
	Uses advised against	Consumer use
1.3. Details of the supplier of the safety data sheet	Company identification	BOC, Priestley Road, Worsley, Manchester M28 2UT
	E-Mail Address	ReachSDS@boccom
1.4. Emergency telephone number	Emergency phone numbers (24h):	0800 111 333

#### II. Hazards Identification

2.1. Classification of the substance or mixture	Classification acc. to Regulation (EC) No. 1272/2008/EC (CLP/GHS)	Press. Gas (Compressed gas) - Contains gas under pressure; may explode if heated.
	Classification acc. to Directive 67/548/EEC & 1999/45/EC	Not classified as hazardous to health.
	Risk advice to man and the environment	Liquefied gas.

<b>2.2.</b> Label elements	Labelling Pictograms			
	Signal word	Warning		
	Hazard Statements	H280	Contains gas under pressure; may explode if heated	
		EIGA-As	Asphyxiant in high concentrations	
	Precautionary Statements	Precautionary Statement Prevention	None	
		Precautionary Statement Response	None	
		Precautionary Statement Storage P403	Store in a well- ventilated place	
Precautionary Statement Disposal		None		

### III. Composition/Information on Ingredients

<b>Substance / Mixture:</b>	Substance	
<b>3.1.</b> Substances	Substances	Carbon dioxide
	CAS No:	124-38-9
	EC No (from EINECS):	204-696-9
	REACH Registration number:	Listed in Annex IV/V of Regulation (EC) No 1907/2006 (REACH), exempted from registration. Contains no other components or impurities which will influence the classification of the product
<b>3.2.</b> Mixtures	Not applicable	

### IV. First Aid Measures

<b>4.1.</b> Description of first aid measures	First Aid General Information:	Remove victim to uncontaminated area wearing self-contained breathing apparatus. Keep victim warm and rested. Call a doctor. Apply artificial respiration if breathing stopped.
	First Aid Inhalation:	Remove victim to uncontaminated area wearing self-contained breathing apparatus. Keep victim warm and rested. Call a doctor. Apply artificial respiration if breathing stopped.
	First Aid Skin / Eye:	In case of frostbite spray with water for at least 15 minutes. Apply a sterile dressing. Obtain medical assistance. Immediately flush eyes thoroughly with water for at least 15 minutes.

	First Aid Ingestion:	Ingestion is not considered a potential route of exposure.
<b>4.2. Most important symptoms &amp; effects, both acute &amp; delayed</b>	In high concentrations may cause asphyxiation. Symptoms may include loss of mobility/consciousness. Victim may not be aware of asphyxiation. Low concentrations of CO <sub>2</sub> cause increased respiration and headache.	
<b>4.3. Indication of any immediate medical attention and special treatment needed</b>	None.	

### V. Fire Fighting Measures

<b>5.1. Extinguishing media</b>	Suitable extinguishing media	All known extinguishants can be used.
<b>5.2. Special hazards arising from the substance or mixture</b>	Specific hazards	Exposure to fire may cause containers to rupture/explode.
	Hazardous combustion products	None.
<b>5.3. Advice for fire-fighters</b>	Specific methods	If possible, stop flow of product. Move container away or cool with water from a protected position.
	Special protective equipment for fire-fighters	In confined space use self-contained breathing apparatus.

### VI. Accidental Release Measures

<b>6.1. Personal precautions, protective equipment and emergency procedures</b>	Evacuate area. Wear self-contained breathing apparatus when entering area unless atmosphere is proved to be safe. Ensure adequate air ventilation. Prevent from entering sewers, basements and workpits, or any place where its accumulation can be dangerous.
<b>6.2. Environmental precautions</b>	Try to stop release.
<b>6.3. Methods and material for containment and cleaning up</b>	Ventilate area.
<b>6.4. Reference to other sections</b>	See also sections 8 and 13.



## VII. Handling And Storage

<p><b>7.1. Precautions for safe handling</b></p>	<p>Suck back of water into the container must be prevented. Do not allow backfeed into the container. Use only properly specified equipment which is suitable for this product, its supply pressure and temperature. Contact your gas supplier if in doubt. Check regularly tightness of the plant. Refer to supplier's handling instructions. The substance must be handled in accordance with good industrial hygiene and safety procedures. Purge system with dry inert gas (e.g. helium or nitrogen) before gas is introduced and when system is placed out of service. Do not smoke while handling product. Only experienced and properly instructed persons should handle gases under pressure. Protect cylinders from physical damage; do not drag, roll, slide or drop. Never use direct flame or electrical heating devices to raise the pressure of a container. Do not remove or deface labels provided by the supplier for the identification of the cylinder contents. When moving cylinders, even for short distances, use a cart (trolley, hand truck, etc.) designed to transport cylinders. Leave valve protection caps in place until the container has been secured against either a wall or bench or placed in a container stand and is ready for use. Ensure the complete gas system has been (or is regularly) checked for leaks before use. If user experiences any difficulty operating cylinder valve discontinue use and contact supplier. Close container valve after each use and when empty, even if still connected to equipment. Never attempt to repair or modify container valves or safety relief devices. Damaged valves should be reported immediately to the supplier. Replace valve outlet caps or plugs and container caps where supplied as soon as container is disconnected from equipment. Keep container valve outlets clean and free from contaminates particularly oil and water. Never attempt to transfer gases from one cylinder/container to another. Avoid suck back of water, acid and alkalis.</p>
<p><b>7.2. Conditions for safe storage, including any incompatibilities</b></p>	<p>Secure cylinders to prevent them from falling. Keep container below 50°C in a well ventilated place. Observe all regulations and local requirements regarding storage of containers. Containers should not be stored in conditions likely to encourage corrosion. Containers should be stored in the vertical position and properly secured to prevent falling over. Stored containers should be periodically checked for general conditions and leakage. Container valve guards or caps should be in place. Store containers in location free from fire risk and away from sources of heat and ignition. Keep away from combustible materials.</p>
<p><b>7.3. Specific end use(s)</b></p>	<p>None.</p>

## VIII. Accidental Release Measures

<p><b>8.1. Control parameters</b></p>	<p>Exposure limit value</p>	
<p><b>8.2. Exposure controls</b></p>	<p>Appropriate engineering controls</p>	<p>Product to be handled in a closed system. Gas detectors should be used when toxic quantities may be released. Keep concentrations well below occupational exposure limits. Oxygen detectors should be used when asphyxiating gases may be released. The substance must be handled in accordance with good industrial hygiene and safety procedures. Consider work permit system e.g. for maintenance activities. Systems under pressure should be regularly checked for leakages. Provide adequate general or local ventilation.</p>

	Personal protective equipment	Eye and face protection	Safety eyewear, goggles or face shield to EN166 should be used to avoid exposure to liquid splashes.
		Skin protection	
		Other protection	Wear leather safety gloves and safety shoes when handling cylinders.
		Respiratory protection	Not required
		Thermal hazards	Not required
		Environmental Exposure Controls	Specific risk management measures are not required beyond good industrial hygiene and safety procedures. Refer to local regulations for restriction of emissions to the atmosphere. See section 13 for specific methods for waste gas treatment.

## IX. Physical And Chemical Properties

<b>9.1.</b> <b>Information on basic physical and chemical properties.</b> <b>General information</b>	Appearance/Color:	Colorless gas.
	Odor:	No odor warning properties.
	Melting point:	-56,6 °C
	Boiling point:	-78,5 °C
	Flash point:	Not applicable for gases and gas mixtures.
	Flammability range:	Nonflammable.
	Vapor Pressure 20 °C:	57,3 bar
	Relative density, gas:	1,52
	Solubility in water:	2000 mg/l
	Partition coefficient: n-octanol/water:	0,83 log Pow
	Autoignition temperature:	Not applicable.
	Explosive properties:	Not explosive.
	Explosive acc. EU legislation:	
	Explosive acc. transp. Reg.:	Not explosive.
	Oxidizing properties:	Not applicable.
	Molecular weight:	44 g/mol
Sublimation point:	-78,5 °C	
Critical temperature:	31 °C	
Relative density, liquid:	1,03	
<b>9.2.</b> <b>Other information</b>	Gas/vapor heavier than air. May accumulate in confined spaces, particularly at or below ground level.	

## X. Stability And Reactivity

10.1. Reactivity	Unreactive under normal conditions
10.2. Chemical stability	Stable under normal conditions
10.3. Possibility of hazardous reactions	None
10.4. Conditions to avoid	None
10.5. Incompatible materials	For material compatibility see latest version of ISO-11114
10.6. Hazardous decomposition products	Under normal conditions of storage and use, hazardous decomposition products should not be produced

## XI. Toxicological Information

11.1. Information on toxicological effects	In high concentrations may cause rapid circulatory insufficiency even at normal levels of oxygen concentration. Symptoms are headache, nausea and vomiting, which may lead to unconsciousness and even death.
---	---

## XII. Ecological Information

12.1. Toxicity	When discharged in large quantities may contribute to the greenhouse effect
12.2. Persistence and degradability	Not applicable
12.3. Bioaccumulative potential	Not applicable
12.4. Mobility in soil	The substance is a gas, not applicable.
12.5. Results of PBT and vPvB assessment	Not classified as PBT or vPvB.
12.6. Other adverse effects	When discharged in large quantities may contribute to the greenhouse effect. Global Warming Potential GWP: 1

## XIII. Disposal Considerations

13.1. Waste treatment methods	Do not discharge into any place where its accumulation could be dangerous. Vent to atmosphere in a well ventilated place. Discharge to atmosphere in large quantities should be avoided. Contact supplier if guidance is required. <b>EWC Nr. 16 05 05</b>
----------------------------------	---

## XIV. Transport Information

ADR/RID	
14.1. UN number	1013
14.2. UN proper shippingname	Carbon dioxide
14.3. Transport hazardclass(es)	Class: 2 Classification Code: 2A Labels: 2.2 Hazard number: 20 Emergency Action Code: 2T
14.4. Packing group (Packing Instruction)	P200
14.5. Environmental hazards	None.
14.6. Special precautions foruser	None.
IMDG	
14.1. UN number	1013
14.2. UN proper shippingname	Carbon dioxide
14.3. Transport hazardclass(es)	Class 2.2 Labels: 2.2 EmS: FC, SV
14.4. Packing group (Packing Instruction)	P200
14.5. Environmental hazards	None.
14.6. Special precautions for user	None.
14.7. Transport in bulk according to Annex II of MARPOL73/78 and the IBC Code	Not applicable.
IATA	
14.1. UN number	1013
14.2. UN proper shippingname	Carbon dioxide
14.3. Transport hazardclass(es)	Class: 2.2 Labels: 2.2

<b>14.4.</b> Packing group (Packing Instruction)	P200
<b>14.5.</b> Environmental hazards	None.
<b>14.6.</b> Special precautions for user	None.
<b>Other transport information</b>	Avoid transport on vehicles where the load space is not separated from the driver's compartment. Ensure vehicle driver is aware of the potential hazards of the load and knows what to do in the event of an accident or an emergency. Before transporting product containers ensure that they are firmly secured. Ensure that the cylinder valve is closed and not leaking. Ensure that the valve outlet cap nut or plug (where provided) is correctly fitted. Ensure that the valve protection device (where provided) is correctly fitted. Ensure adequate Ventilation. Ensure compliance with applicable regulations.

**XV. Regulatory/Other Information**

<b>Other information</b>	Ensure all national/local regulations are observed. The hazard of asphyxiation is often overlooked and must be stressed during operator training. Before using this product in any new process or experiment, a thorough material compatibility and safety study should be carried out.
<b>Advice</b>	Whilst proper care has been taken in the preparation of this document, no liability for injury or damage resulting from its use can be accepted. Details given in this document are believed to be correct at the time of going to Press.
<b>Further information</b>	Note: When using this document care should be taken, as the decimal sign and its position complies with rules for the structure and drafting of international standards, and is a comma on the line. As an example 2,000 is two (to three decimal places) and not two thousand, whilst 1.000 is one thousand and not one (to three decimal places).

**IMPORTANT INFORMATION REGARDING THE REFRIGERANT USED**

This product contains natural refrigerant. Do not dispose of such gases in the environment.

Type of refrigerant: **R744**

GWP value: **1**

GWP is the global warming potential

The amount of refrigerant is shown on the plate with the name of the unit. It is possible that routine inspections will be required to check for leaking refrigerant in accordance with local, United States and/or Canadian standards. Contact your local Lync rep for additional information.