

TECHNICAL DATA	
UNIT WEIGHT (Lb/Kg)	625 / 284.5
SHIPPING WEIGHT (Lb/Kg)	725 / 328.9
UNIT DIMENSIONS L X W X H (in/mm)	39.50 X 31.75 X 57.26 (1003 X 806 X 1454)
SHIPPING DIMENSIONS L X W X H (in/mm)	48 X 41 X 66 (1219 X 1041 X 1676)
HX SURFACE AREA (ft ² /m ²)	121 / 11.24
PRIMARY LOOP, MAWP (PSI/KPa)	150 / 1034.21
DHW SIDE, MAWP (PSI/KPa)	150 / 1034.21
ELECTRICAL DATA ON PRIMARY PUMP	115VAC 60Hz W/ 2.4A
ELECTRICAL DATA ON SECONDARY PUMP	115VAC 60Hz W/ 2.4A

- NOTES:
 1) ALL DIMENSIONS SHOWN ARE IN INCHES (MILLIMETERS).
 2) LYNCO RESERVES THE RIGHT TO MODIFY DIMENSIONS WITHOUT PRIOR NOTICE.

	Blauvelt, NY Fort Worth, TX	
	AEGIS MK II DUAL HEAT EXCHANGER MODULE DIMENSIONAL/CLEARANCE DRAWING	
DWN. BY <u>K.S.</u> DATE <u>031323</u> SCALE <u>NTS</u> REV. BY <u>K.S.</u> DATE <u>092324</u>	AP-L-1086 (SHEET 1 OF 2)	REV. D

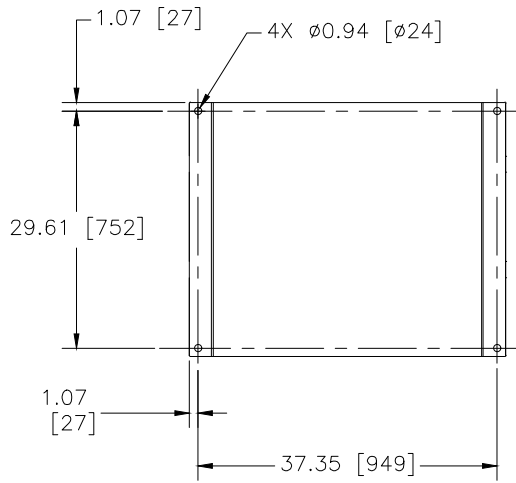

ANCHOR BOLT LOCATIONS

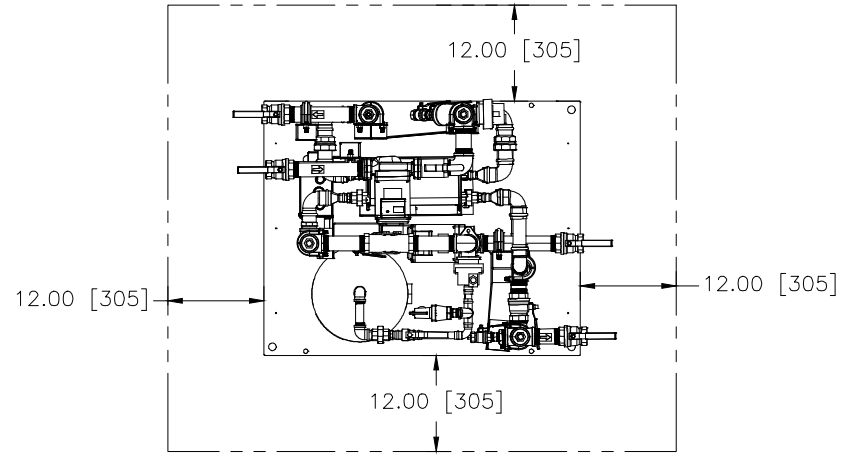

RECOMMENDED CLEARANCE

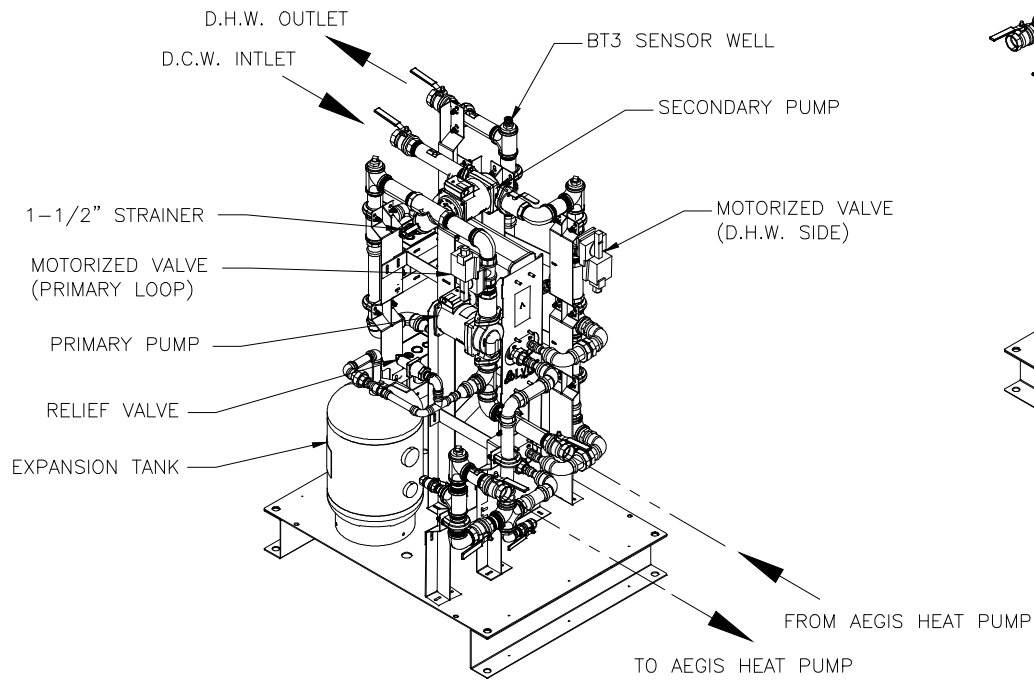

RIGHT SIDE ISO VIEW

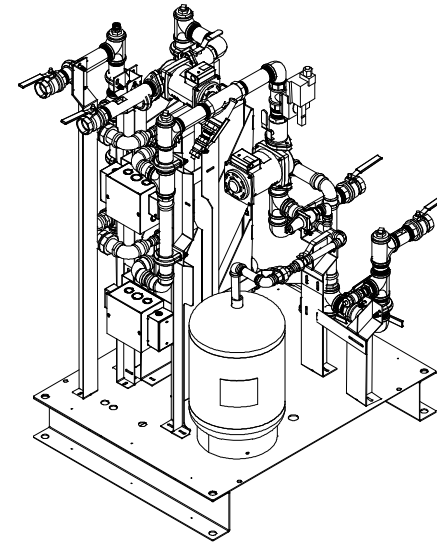

LEFT SIDE ISO VIEW

		Blauvelt, NY Fort Worth, TX	
		AEGIS MK II DUAL HEAT EXCHANGER MODULE DIMENSIONAL/CLEARANCE DRAWING	
DWN.BY <u>K.S.</u> DATE <u>031323</u> SCALE <u>NTS</u> REV.BY _____ DATE _____	<u>AP-L-1086</u> (SHEET 2 OF 2)	REV. <u>D</u>	